

Lens orienting rib

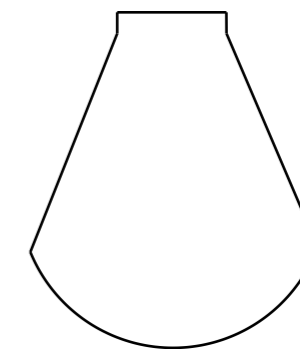

Beam shape

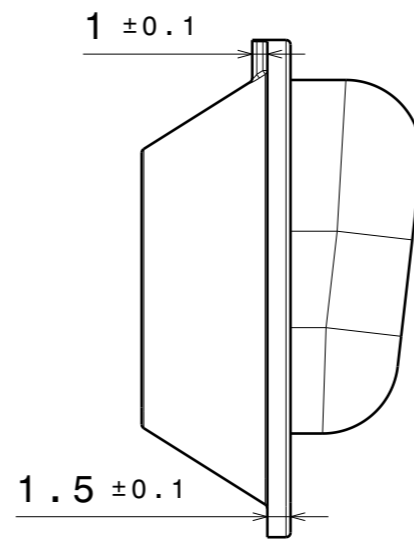
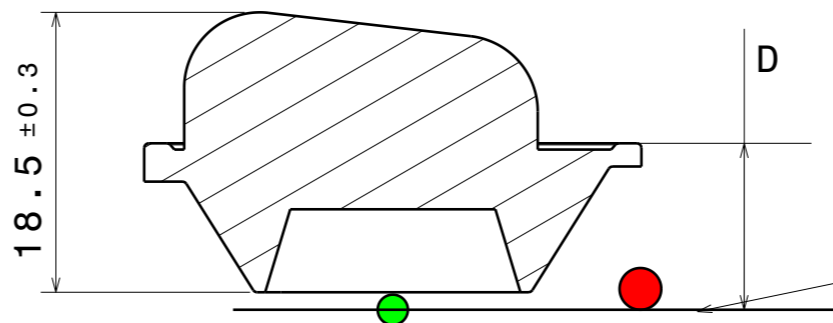
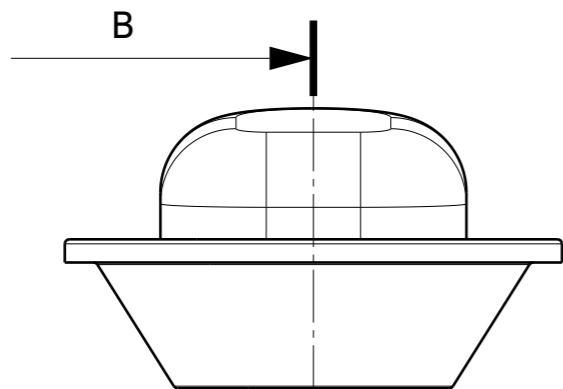

PCB top level

Dimension D according to the LED:
- Luxeon Altilon intense 1x1 and 1x2 chip: D= 10 ± 0.1mm

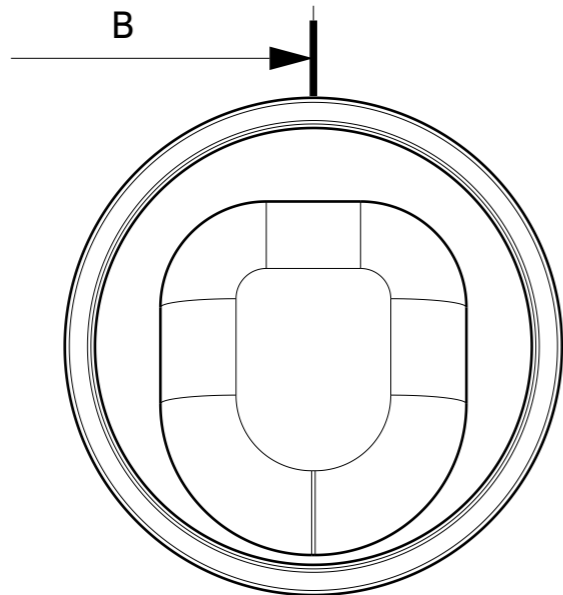

PART	TYPE	MATERIAL	COLOR / COATING
C18612_Filippa	LENS	PMMA	CLEAR

MECHANICAL DRAWING

PRODUCT
FILIPPA

LEDiL

Plastic moulding general tolerances according to DIN 16901-130 and applies if not otherwise shown in the drawing. Silicone moulding general tolerances according to ISO 3302-1 Class M3 and applies if not otherwise shown in the drawing.

FIRST ANGLE PROJECTION:

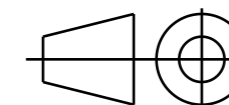

This drawing is the property of LEDiL Oy. It may not be copied or otherwise distributed without prior written permission from LEDiL Oy.

SCALE 1:1

WEIGHT 6.3g

A3 SHEET 1/1

Notes

	PCB or heatsink level.
	LED location
	Ensure LED fitting from a product specific 3D model available from www.ledil.com
	For more details about installation please see LEDiL Installation Guide on www.ledil.com